

CENTRIFUGALLY SPUN CAST
Ductile Iron
SOCKET SPIGOT PIPES

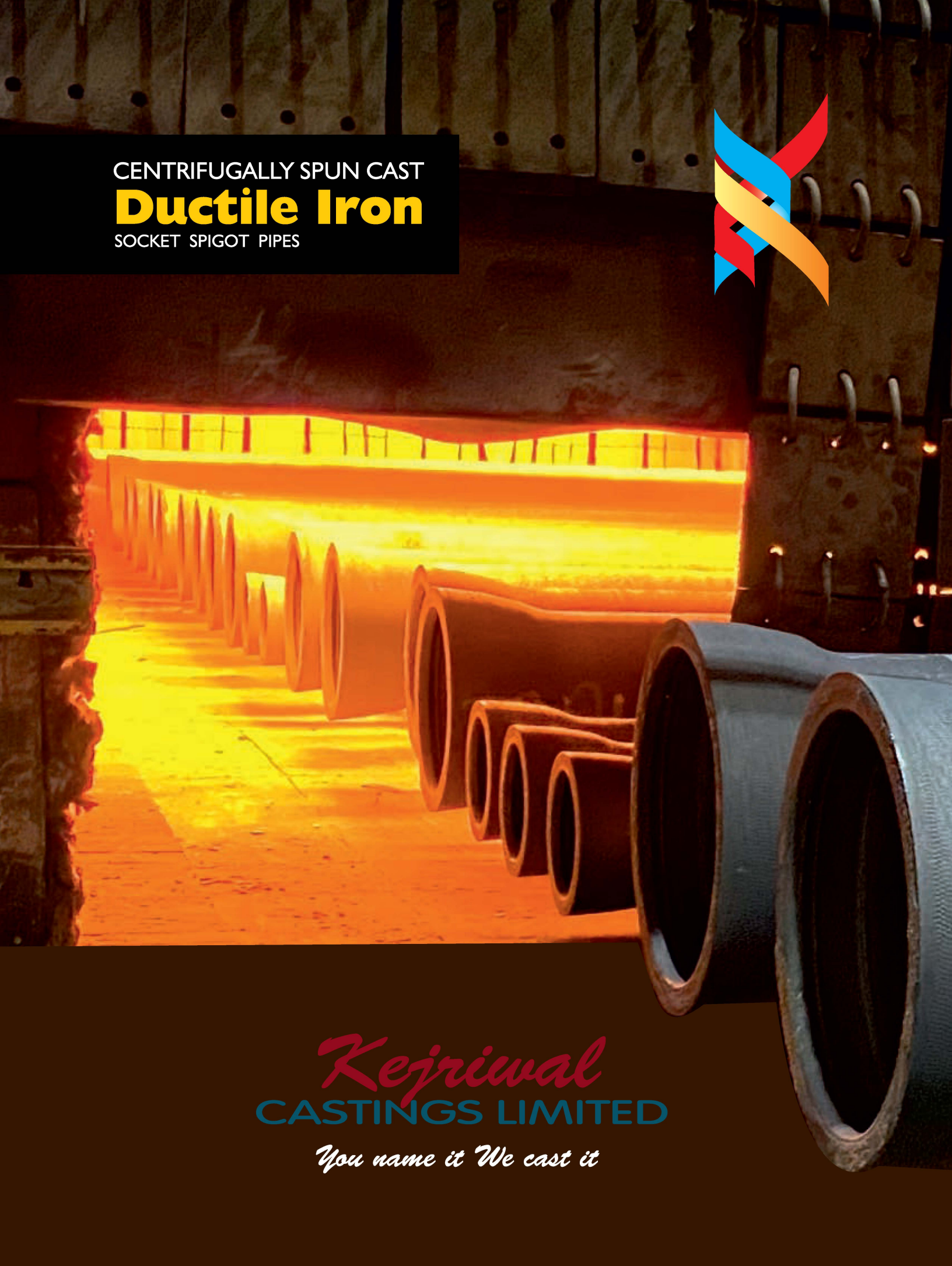

Kejriwal
CASTINGS LIMITED

You name it We cast it

Ductile iron pipe is made of Ductile Cast Iron commonly used for potable water transmission and distribution, as well as sewage application & irrigation. This type of pipe is a direct development of earlier cast iron pipe, which it has superseded.



Kejriwal

At *Kejriwal*, we strictly believe in providing convenience above all, and as such all 3 major components of any pipe line viz: pipe, fitting & valve are manufactured inhouse under strict quality control parameters, so that compatibility is never an issue, and peace of mind is assured.

Since its inception in 1950's, quality has been the bedrock of its foundation, with a Customer First attitude. An attitude that has helped Team 'Kejriwal' to identify the areas of:

Improvement : The never ending quest for improvement in quality, customer relations and time management.

Innovation : Trying out new practices and methods to reach the final frontier of customer satisfaction

Inspiration : The positive feedback from our valued customers provides us the inspiration to move the mark upwards and work still harder.

Our plant encompasses a lot of exciting features in offering a variety of Ductile iron pipes with exotic features:

Different linings & coatings, like SRC, HAC, Epoxy, FBE, PU etc.

Different end connections like push on joints, restrained joints, bolted joints etc.

To suit your specific requirements depending upon site conditions, soil conditions and topography.

At *Kejriwal* challenges are but a stepping stone to climb higher.

Team *Kejriwal* strives to achieve...
what others fail to comprehend.





Kejriwal
CASTINGS LIMITED

... has another first to its credit

THE ONLY MANUFACTURER IN INDIA
having facilities to manufacture

DUCTILE IRON PIPES | DUCTILE IRON FITTINGS
DUCTILE IRON VALVES

...under one banner

Kejriwal

the name to trust.

ISO 9001, 14001, 45001 Certificates



NABL



One Pipe many Applications

- Raw and clear water transmission through pumping and gravity main.
- Water distribution network.
- Lift and gravity irrigation systems
Sewerage and waste water pumping main.
- Gravity sewerage collection and disposal system.
- Storm water drainage piping.
- Effluent disposable system for domestic and industrial applications.
- Ash-Slurry Handling and disposal system in power plants.
- Fire fighting system - on-shore and off-shore.
- Desalination plants.
- OHR & UGR connections.

Maintaining High Standards

- Domestic National Standard
IS 8329-2000
- Equivalent International Standards
BE EN 545:2010
BE EN 598:2010
ISO 2531:2009
ISO 7186:2009
- Classes:
K-7, K-9, C-25, C-30, C-40, C-50, C-64, C-100
- Nominal Diameter:
DN 80 to DN 400

Choose from range of Protection Systems:

- **Based on External Coating**
Zinc coating followed by Bitumen, Epoxy, Polyurethane & FBE Coating
- **Based on Internal Lining**
Cement Mortar Lining, Epoxy Lining, Polyurethane Lining, & FBE Lining
- **Cement types**
High Alumina Cement, Blast Furnace Slag Cement (BFSC), Portland Slag Cement (PSC) & Sulphate Resistant Cement (SRC)
- **Full range of in-house testing facilities**



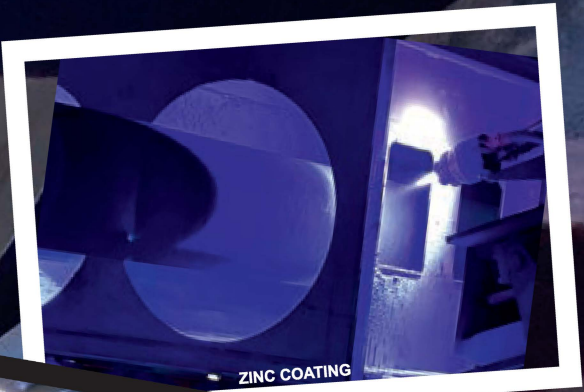

ZINC COATING



POLYURETHANE COATING



EPOXY COATING



BITUMIN COATING



FBE COATING

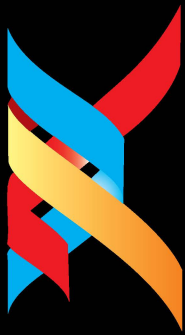

Flow Chart



Molten Iron



Induction Furnace



Centrifugal Casting



Annealing



Hydraulic Testing



Cement Lining



under strict Quality Process



Spherodization



Core Making

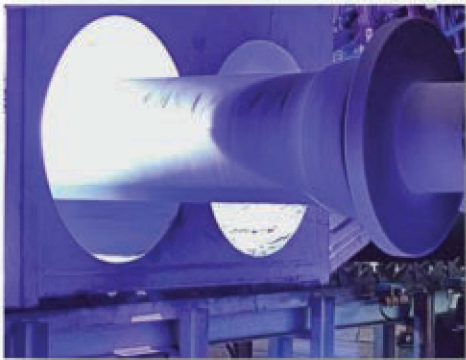

Zinc Spray



Grinding



Bitumen Coating



Packing



Ductile Iron Pipes

Ductile Iron pipes is an alloy of Iron, Carbon and Silicon. If we observe the micro structure of grey cast iron, we will notice that graphite present in it is in the form of flakes. In the year 1948, the flake structure of graphite was modified to spheroid or nodules by adding magnesium to the molten metal. The resultant product of grey cast iron is now

typically known as Ductile Iron or S.G. Iron.

The use of Ductile iron Pipe has gone up at a rapid rate over the last 60 years because of its proven external corrosion protective coating and cost effective internal linings as well as higher tensile strength, yield strength, ductility and impact resistance.

ADVANTAGES OF DUCTILE IRON PIPES

- Low cost, Hi performance, Easy Installation, Complete Reliability, Longer life
- High Tensile & Yield Strength
- High Elongation (Ductility)
- High impact Resistance ensures reduction in Handling & Transportation Damage
- Tremendous Bursting Strength
- Simple Push-on type Leak proof Rubber Gasket Jointing means Easy Installation
- Reliable and Cost Effective Internal and External Corrosion Protection
- Larger effective internal diameter increases flow capacity
- Higher "C" value (C= 140, Hazen William's Constant) ensures lower friction loss, lower head loss and hence reduces pumping cost.
- Capable of angular deflection & axil withdrawal, providing opportunity to reduce the fittings required.
- Install, Test & Forget, less supervision on site.
- Practical weldability of pipes at site for house connections possible.



Photomicrograph of Grey Cast Iron (100X) showing carbon in the form of graphite flakes.

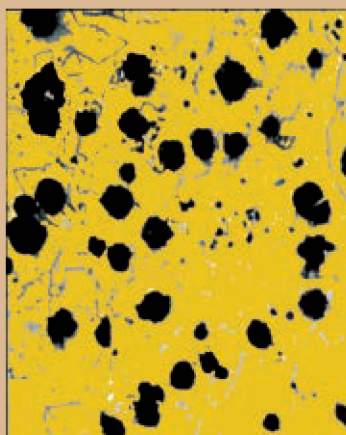

Photomicrograph of Ductile Cast Iron (100X) showing carbon in the form of graphite nodules.

PIPE JOINT

The standard joints for the pipes are designed so that contact pressure between the gaskets and the metal increase as the water pressure increases, thus a perfect seal is guaranteed.

The rubber gasket for the pipes is standard type which is known as Push-on Joints and are of EPDM rubber quality.

PIPE DEFLECTION

- Kejriwal socket-spigot joints permits angular deflection which gives the following advantages:
- Accomodation of ground movement
- Allowing adjustments during installation
- Reducing the number of bends required.

PERMISSIBLE DEFLECTION OF EACH JOINT IN DEGREE

Where it is necessary to deflect the pipe line from a straight line, either in the vertical or horizontal plane, to avoid obstructions etc. deflection at joint should not exceed:

PUSH-ON JOINT	DEVIATION JOINT
80 - 200 mm	5°
250 - 350 mm	4°
400 - 600 mm	3°
700 - 900 mm	2°3'
1000 - 1100 mm	2°

DIMENSIONS OF CLASS K-7, K-8, K-9, K-10 & K-12 PIPES

Nominal Diameter	External Diameter	Socket Mass	Barrel Wall Thickness 'e'					Approx Mass Per mtr. including socket				Approx Mass Per Pc. 5.5 mtr. including socket			
			K7	K8	K9	K10	K12	Tar Coated		Cement Lined		Tar Coated		Cement Lined	
DN	DE						K-7	K-9	K-7	K-9	K-7	K-9	K-7	K-9	
80	98	3.4	5	6	6	6	7	10.91	12.84	12.61	14.54	60	71	69	80
100	118	4.3	5	6	6	6.1	7.2	13.29	15.66	15.39	17.76	73	86	85	98
125	144	6.0	5	6	6	6.3	7.5	16.43	20.00	20.50	24.27	90	110	113	133
150	170	7.1	5	6	6	6.5	7.8	19.55	23.07	22.75	26.27	108	127	125	144
200	222	10.3	5	6	6.3	7	8.4	25.89	31.95	30.09	36.15	142	176	165	199
250	274	14.2	5.3	6	6.8	7.5	9.0	34.11	42.80	39.31	48.00	188	235	216	264
300	326	18.6	5.6	6.4	7.2	8	9.6	43.10	54.19	49.40	60.49	237	298	272	333
350	378	23.8	6	6.8	7.7	8.5	10.2	53.72	67.43	66.02	79.73	295	371	363	439
400	429	29.3	6.3	7.2	8.1	9	10.8	64.28	80.80	78.28	94.80	354	444	431	521

Note : In addition to popular K-7 & K-9, we can manufacture K-8, K-10 & K-12 class pipes also.

DIMENSIONS OF 'C' CLASS OF PIPES

DM mm	DE ^a mm	Nominal Iron Wall thickness, e_{nom} mm ^b						
		C20	C25	C30	C40	C50	C64	C100
40	56				4.4	4.4	4.4	4.4
50	66				4.4	4.4	4.4	4.4
60	77				4.4	4.4	4.4	4.4
65	82				4.4	4.4	4.4	4.4
80	98				4.4	4.4	4.4	4.8
100	118				4.4	4.4	4.4	5.5
125	144				4.5	4.5	4.8	6.5
150	170				4.5	4.5	5.3	7.4
200	222				4.7	5.4	6.5	9.2
250	274				5.5	6.4	7.8	11.1
300	326			5.1	6.2	7.4	8.9	12.9
350	378		5.1	6.3	7.1	8.4	10.2	14.8
400	429		5.5	6.5	7.8	9.3	11.3	16.5

MECHANICAL PROPERTIES

Nominal Diameter (DN) mm	Minimum Tensile Strength (MPa)	Minimum Elongation at break (%)	Minimum Elongation at Break Hardness (HB)
80-400	420	10	230

WORKS TEST PRESSURE FOR DI S & S PIPE

Nominal Bore	S/S Pipes		
	K-7	K-8	K-9, K-10
80-300	32	40	50
350-600	25	32	40
700-1000	18	25	32

Push-on Joint 'T' Type

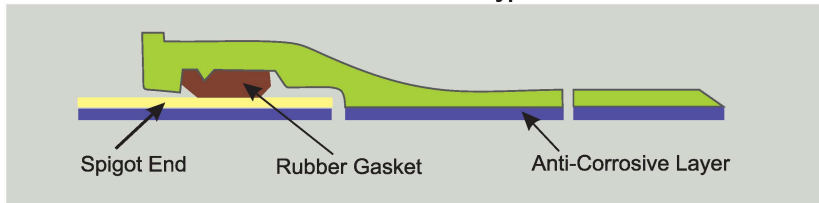

PUSH ON JOINT

Push on joint has been accepted throughout the world as the most successful flexible pipe joint. It has every quality a pipe joint should have.

- The jointing process is easy and quick
- The joint is watertight and long lasting
- Deflection and disengagement is easy

The gasket has two sections having different hardness. The harder heel of the gasket lock perfectly into the groove provided in the socket. The softer bulb gives the positive seal when the spigot is pushed in, to give a permanent water tight joint.

TYPE OF RUBBER & HARDNESS

The socket profile and compatible rubber gasket are to be designed by the manufacturer. Kejriwal's

design of the socket and the rubber gasket ensures leak-tight joint through Type Test. It is advised that the user should obtain gaskets through Kejriwal only.

FLANGED PIPES (Welded-on)

Flanged Joints are self-restrained rigid joints. Kejriwal manufactures flanged pipes with working pressure ratio of 1.0 MPa (PN-10), 1.6 Mpa (PN-16), 2.5 Mpa (PN-25), & 4.0 Mpa (PN-40) as per prescribed length. The flanged pipes made by Kejriwal are welded on type as well as screwed type. For flanged pipes the minimum class per working pressure criteria is K9 or equivalent.

WORKS TEST PRESSURE FOR FLANGED DI PIPES

Nominal Dia	PN 10	PN 16	PN 25	PN 40
90-300	1.6 MPa	2.5 MPa	3.2 Mpa	4.0 Mpa
350-600	1.6 MPa	2.5 MPa	3.2 Mpa	4.0 Mpa
700-1000	1.6 MPa	2.5 MPa	3.2 Mpa	--
1100 - 1200	1.6 Mpa	2.5 Mpa	2.5 Mpa	--



ISO 8329 | EN-545 | EN 598 | ISO 2531 | ISO 7186

ASSEMBLY OF PUSH-ON JOINT

- The method described below is given as an example. The method of making the joint and equipment used may vary, providing of course that the principals of assembling and recommendations specified will be strictly observed
- Using a wire brush and a rag, carefully clean the inside of the socket particularly the gasket recesses. In particular, move any deposits of the earth, sand etc. and also clean the spigot of the pipe to be joined and the gasket itself. Check the presence of the chamfer, as well as the absence of any damage on the spigot of the pipe.
- Check the condition of the gasket and insert it into the recess, with the lips pointing towards the bottom of the socket. Make sure that the gasket is correctly compressed all the way round.
- The gasket recess must not be coated with lubricating paste, except for small diameter of pipes when problem arise on fitting the gasket.
- Centre the spigot in the socket and hold the pipe in a position by resting it on two wedges of tamped earth or better, gravel.
- Push in the spigot until the first mark disappears inside the socket. The second mark must still be visible after assembly.
- Check that the gasket is correctly in position by inserting the end of a metal



ruler through the annular spigot and socket gap until touches the gasket. The ruler must penetrate to the same depth around the whole circumference.

- Jointing must be done with well aligned pipes. Make sure that the curvature after assembly does not exceed the permissible angular deflection of particular joint.

CUTTING PIPES

Pipes must be cut on site as infrequently as possible by using disc-type cutter. Such operations, which require particular care, must be carried out without fail in a plane perpendicular to the pipe axis.

Before cutting, make sure that the OD of the new spigot 'Cut Area' is within tolerance of the OD of the old spigot. It is advisable to use guage pipe for cutting on site. Guage pipe has a special mark on the socket face. After cutting the pipe, it is necessary.

- To restore the chamfer at the spigot end of the cut faces of pipe.
- To repair the pipe coating and cement lining if damaged.

CHAMFER RESTORATION

After cutting, complete deburring is recommended. It is essential to restore the chamfer on the cut faces of standard pipes so as to facilitate the assembly of the push-on joint and to prevent any damage to the elastomer (rubber) gasket, which can result in a leaking joint.

REPAIR OF CEMENT LINING

Any damage in the internal mortar lining caused accidentally during transportation, storage, laying or by rough handling can be repaired easily on site.

- The damage area should be less than 0.1m^2
- The length of the damage area should not exceed a quarter of pipe circumference.
- No localised deformation otherwise cut off the damage area.



Ductile Pipes

Classification

Pipes have been classified in this standard as K7, K8, K9 and K10 according to their thickness. K7 pipes have minimum wall thickness where K10 has maximum.

TOLERANCE ON LENGTH

- a. Socket & Spigot and Plain end Pipes = ± 100 mm
- b. Flanged Pipes = ± 10 mm

COATINGS

- a. Pipes are normally externally coated with Black Bituminous paint after zinc metallisation
- b. Suitable cement mortar lining is normally done internally.
- c. Different types of external coatings are available as per requirements.

S/S Pipes = Socket/Spigot Pipes

D/F Pipes = Double Flanged Pipes



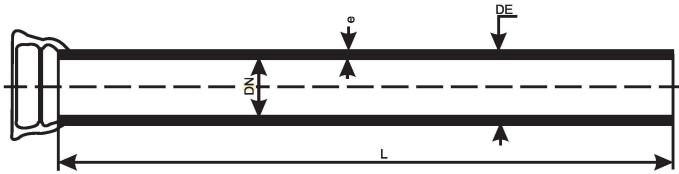

**DIMENSIONS OF
SOCKET AND SPIGOT PIPES, CLASS K7, K8, K9 & K10**

Nominal Diameter	External Diameter	Socket Mass	Barrel Wall Thickness 'e'				Approx Mass Per mtr. including socket				Approx Mass Per Pc. 5.5 mtr. including socket			
							Tar Coated		Cement Lined		Tar Coated		Cement Lined	
DN	DE		K7	K8	K9	K10	K-7	K-9	K-7	K-9	K-7	K-9	K-7	K-9
80	98	3.4	5	6	6	6	10.91	12.84	12.61	14.54	60	71	69	80
100	118	4.3	5	6	6	6.1	13.29	15.66	15.39	17.76	73	86	85	98
125	144	6.0	5	6	6	6.3	16.43	20.00	20.50	24.27	90	110	113	133
150	170	7.1	5	6	6	6.5	19.55	23.07	22.75	26.27	108	127	125	144
200	222	10.3	5	6	6.3	7	25.89	31.95	30.09	36.15	142	176	165	199
250	274	14.2	5.3	6	6.8	7.5	34.11	42.80	39.31	48.00	188	235	216	264
300	326	18.6	5.6	6.4	7.2	8	43.10	54.19	49.40	60.49	237	298	272	333
350	378	23.8	6	6.8	7.7	8.5	53.72	67.43	66.02	79.73	295	371	363	439
400	429	29.3	6.3	7.2	8.1	9	64.28	80.80	78.28	94.80	354	444	431	521
450	480	36.0	6.6	7.6	8.6	9.5	75.71	95.27	91.41	110.97	416	524	503	610
500	532	42.8	7	8	9	10	89.14	111.98	106.64	129.48	490	616	587	712
600	635	59.3	7.7	8.8	9.9	11	117.71	147.78	138.61	168.63	647	813	762	927
700	738	79.1	8.4	9.6	10.8	12	159.62	188.24	188.92	217.54	878	1035	1039	1196
750	790	90.0	8.7	10	11.3	12.5	184.06	211.30	215.36	242.60	1012	1162	1184	1334
800	842	103	9.1	10.4	11.7	13	210.11	233.70	243.51	267.10	1156	1285	1339	1469
900	945	130	9.8	11.2	12.6	14	255.14	283.69	292.74	321.29	1403	1560	1610	1767
1000	1048	162	10.5	12	13.5	15	304.53	338.49	346.23	380.19	1675	1862	1904	2091
1100	1152	200	11.2	12.8	14.4	16	--	405.00	--	458.0	--	2228	--	2519
1200	1255	238	11.9	13.9	15.3	17	--	460.00	--	520.0	--	2530	--	2860
1400	1462	280	--	--	17.1	--	--	600.00	--	675.0	--	3300	--	3713
1600	1668	380	--	--	18.9	--	--	760.00	--	850.0	--	4180	--	4675
1800	1875	490	--	--	20.7	--	--	930.00	--	1040.0	--	5115	--	5720
2000	2082	626	--	--	22.5	--	--	1120.00	--	1250.0	--	6160	--	6875
2200	2288	784	--	--	24.3	--	--	1350.00	--	1500.0	--	7425	--	8250
2400	2458	966	--	--	26.1	--	--	1610.00	--	1780.0	--	8855	--	9790
2600	2684	1174	--	--	27.9	--	--	1900.00	--	2100.0	--	10450	--	11550

NOTE : No K7 Pipes from 1100 mm Dia onwards is specified.

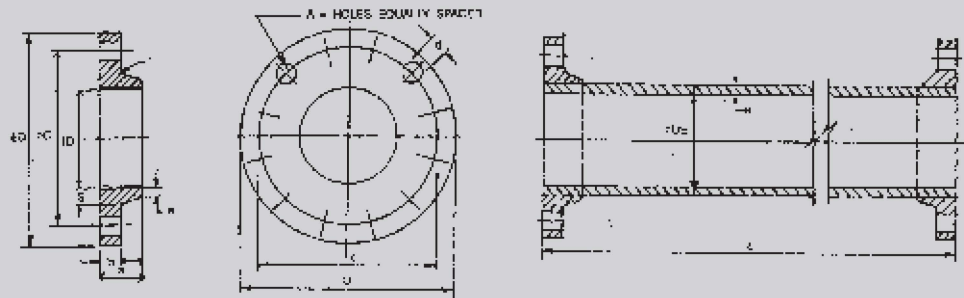

**DIMENSIONS OF
CENTRIFUGALLY CAST DUCTILE IRON PIPES WITH SCREWED / WELDED FLANGES**

Nominal Diameter	Outside Diameter	Wall Thickness	App. Mass of One Flange		App. Mass of Barrel/mtr.	Approx Mass of One working Length "L" including two flanges					
			PN-10	PN-16		PN - 10			PN - 16		
DN	DE	e	PN-10	PN-16	Non-CML	2.75M	5.0M	5.4M	2.75M	5.0M	5.4M
80	98	6.0	3.5	3.5	12.84	42	71	78	42	71	78
100	118	6.0	3.8	3.8	15.66	51	86	94	51	86	94
125	144	6.0	4.7	4.7	20.00	64	109	119	64	109	119
150	170	6.0	5.8	5.8	23.07	75	127	138	75	127	138
200	222	6.3	8.0	8.0	31.95	104	176	191	104	176	191
250	274	6.8	11.0	12.0	42.80	140	236	256	142	238	258
300	326	7.2	15.0	16.0	54.19	179	301	327	181	303	329
350	378	7.7	18.0	23.0	67.43	221	373	406	231	383	416
400	429	8.1	19.0	26.0	80.80	260	442	480	274	456	494
450	480	8.6	22.0	34.0	95.27	306	520	566	330	544	590
500	532	9.0	28.0	46.0	111.98	364	616	670	400	652	706
600	635	9.9	43.0	73.0	147.78	496	829	900	552	885	956
700	738	10.8	62.0	83.0	188.24	642	1065	1155	684	1107	1196
750	790	11.3	74.0	96.0	211.30	729	1205	1306	773	1249	1350
800	842	11.7	82.0	108.0	233.70	807	1333	1445	859	1385	1495
900	945	12.6	92.0	125.0	283.69	964	1602	1740	1030	1668	1805
1000	1048	13.5	126.0	178.0	338.49	1183	1944	2108	1287	2048	2215
1100	1152	14.4	158.0	210.0	367.80	1327	2155	2332	1431	2259	2435
1200	1255	15.3	190.0	270.0	425.80	1551	2509	2715	1711	2669	2875

NOTE :

1. The method of screwing and the exact form of thread are as per our own discretion as the flanges are never removed after screwing on to the barrel of the pipes.
2. If so required the flanges may be spot welded on the back side after screwing.
3. Alternatively the flanges may be completely welded on to the barrel pipes.
4. Pipes = K 9
5. ONLY WELDABLE FLANGES MAY ALSO BE SUPPLIED TO BE WELDED ON TO THE PIPES AS PER SITE REQUIREMENTS
6. PUDDLE flanges (for wall casting) may be welded on pipes as per Customer's requirements.

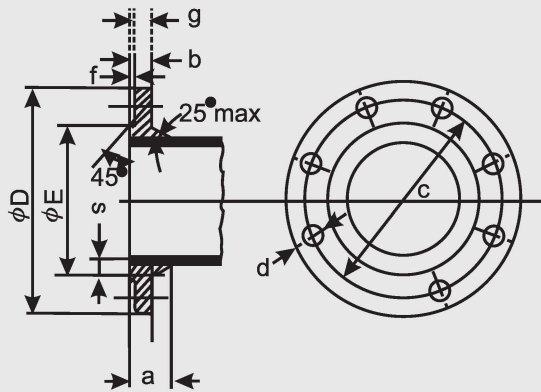

PN-10

DIMENSIONS OF
STANDARD FLANGED DRILLING FOR SCREWED FLANGES AND WELDED FLANGE (PN10)

Nominal Diameter	Dimensions								Holes		Bolt Size Metric	Bolt length mm
	DN	D	E	C	b	f	g	a	S	Number		
80	200	132	160	19	3	16	32	15	4	19	M16	80
100	220	156	180	19	3	16	32	15	8	19	M16	70
125	250	184	210	19	3	16	32	15	8	19	M16	80
150	285	211	240	19	3	16	32	15	8	23	M20	80
200	340	266	295	20	3	17	34	15	8	23	M20	80
250	395	319	350	22	3	19	48	16	12	23	M20	90
300	445	370	400	24.5	4	20.5	52	17.5	12	23	M20	90
350	505	429	460	24.5	4	20.5	52	19.5	16	23	M20	100
400	565	480	515	24.5	4	20.5	60	19.5	16	28	M24	100
450	615	530	565	25.5	4	21.5	63	20	20	28	M24	100
500	670	582	620	26.5	4	22.5	68	21	20	28	M24	110
600	780	682	725	30	5	25	75	24	20	31	M27	120
700	895	794	840	32.5	5	27.5	82	24	24	31	M27	120
750	960	857	900	34	5	29	87	24	24	31	M27	130
800	1015	901	950	35	5	30	90	24.5	24	34	M30	130
900	1115	1001	1050	37.5	5	32.5	98	26.5	28	34	M30	150
1000	1230	1112	1160	40	5	35	105	28	28	37	M33	150
1100	1340	1231	1270	43	5	38	114	30	32	37	M33	160
1200	1455	1328	1380	45	5	40	120	31.5	32	40	M36	180

NOTE :

1. The method of screwing and the exact form of thread shall be left to the discretion of the manufacturer as the flanges are never removed after screwing on the barrels of the pipes.
2. If so required the screwed flanges may be spot welded on the back side after screwing.
3. Dimensions 'a' and 'S' are for guidance only.
4. Unless otherwise specified, flanges shall be of ductile iron.

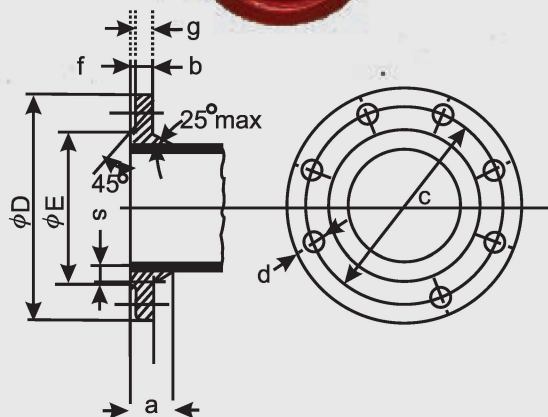

PN-16

DIMENSIONS OF STANDARD FLANGED DRILLING FOR SCREWED FLANGES AND WELDED FLANGE (PN16)

Nominal Diameter	Dimensions								Holes		Bolt Size Metric	Bolt Length mm
	DN	D	E	C	b	f	g	a	S	Number		
80	200	132	160	19	3	16	32	15	8	19	M16	80
100	220	156	180	19	3	16	32	15	8	19	M16	80
125	250	184	210	19	3	16	32	15	8	19	M16	80
150	285	211	240	19	3	16	32	15	8	23	M20	80
200	340	266	295	20	3	17	34	16	12	23	M20	80
250	400	319	355	22	3	19	48	17.5	12	28	M24	90
300	455	370	410	24.5	4	20.5	52	19.5	12	28	M24	100
350	520	429	470	26.5	4	22.5	68	21	16	28	M24	100
400	580	480	525	28	4	24	72	22.5	16	31	M27	110
450	640	548	585	30	4	26	78	24	20	31	M27	110
500	715	609	650	31.5	4	27.5	82	25	20	34	M30	120
600	840	720	770	36	5	31	93	27.5	20	37	M33	130
700	910	794	840	39.5	5	34.5	103	27.5	24	37	M33	140
750	970	857	900	41	5	36	108	28	24	37	M33	140
800	1025	901	950	43	5	38	114	30	24	40	M36	150
900	1125	1001	1050	46	5	41	124	32.5	28	40	M36	160
1000	1255	1112	1170	50	5	45	135	35	28	43	M39	170
1100	1355	1218	1270	53.5	5	48.5	144	37.5	32	43	M39	180
1200	1485	1328	1390	57	5	52	156	40	32	49	M45	200

NOTE :

1. The method of screwing and the exact form of thread shall be left to the discretion of the manufacturer as the flanges are never removed after screwing on the barrels of the pipes.
2. If so required the screwed flanges may be spot welded on the back side after screwing.
3. Dimensions 'a' and 'S' are for guidance only.
4. Unless otherwise specified, flanges shall be of ductile iron.

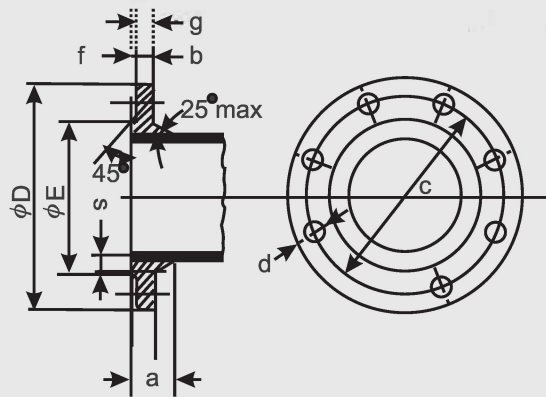

PN-25

DIMENSIONS OF
STANDARD FLANGED DRILLING FOR SCREWED FLANGES AND WELDED FLANGE (PN25)

Nominal Diameter	Dimensions								Holes		Bolt Size Metric	Bolt Length mm
	DN	D	E	C	b	f	g	a	S	Number		
80	200	132	160	19	3	16	32	15	8	19	M16	80
100	235	156	190	19	3	16	33	15	8	23	M20	80
125	270	184	220	19	3	16	37	15	8	28	M24	80
150	300	211	250	20	3	17	40	16	8	28	M24	90
200	360	274	310	22	3	19	44	17.5	12	28	M24	90
250	425	330	370	24.5	3	21.5	49	19.5	12	31	M27	100
300	485	389	430	27.5	4	23.5	56	22	16	31	M27	100
350	555	448	490	30	4	26	57	24	16	34	M30	110
400	620	503	550	32	4	28	64	25.5	16	37	M33	120
450	670	548	600	34.5	4	30.5	69	27.5	20	37	M33	130
500	730	609	660	36.5	4	32.5	73	29	20	37	M33	130
600	845	720	770	42	5	37	83	33.5	20	40	M36	150
700	960	820	875	46.5	5	41.5	84	33.5	24	43	M39	150
750	1020	883	940	50	5	45	100	34	24	43	M39	170
800	1085	928	990	51	5	46	102	35.5	24	49	M45	180
900	1185	1028	1090	55.5	5	50.5	112	39	28	49	M45	190
1000	1320	1140	1210	60	5	55	118	42	28	56	M52	210
1100	1420	1240	1310	65.5	5	60.5	120	45	32	56	M52	210
1200	1530	1350	1420	69	5	64	138	48.5	32	56	M52	220

NOTE :

1. The method of screwing and the exact form of thread shall be left to the discretion of the manufacturer as the flanges are never removed after screwing on the barrels of the pipes.
2. If so required the screwed flanges may be spot welded on the back side after screwing.
3. Dimensions 'a' and 'S' are for guidance only.
4. Unless otherwise specified, flanges shall be of ductile iron.

Carriage & Handling Instructions

TRANSPORTATION

- Improper Handling of DI pipes & fittings can result in damaged coatings & linings.
- All Pipes & Fittings should be loaded with reasonable care to the lorry/container during transit. It should be secured by to the lorry/container to prevent movement.
- Sharp edge of the Lorry/container should not rub on the pipe surface during transportation.



HANDLING & STORAGE

- When fork lift trucks are used for unloading pipes ensure that the fork blades do not damage the pipes or external protection.
- Lift the bundles one by one using slings which surround the Loads and not by means of their straps.
- The lifting machine should be of the type which retains the load safely in the event of a power failure.
- Metal Hooks should not be used, as they may damage the cml.
- Where lifting gear is not available and the mass of the pipes above DN 250, individual pipes should be off loaded by rolling them down a ramp formed of timberskids extending from the vehicle. Suitable steadying rope should be used to prevent excessive speed while rolling.



STACKING

(Three types of stacking are recommended)

Square Stacking :

Each tier of pipe shall be positioned with their axes at right angle, to those of the preceeding tier to form a stable and compact stack. Suitable upto DN 400.

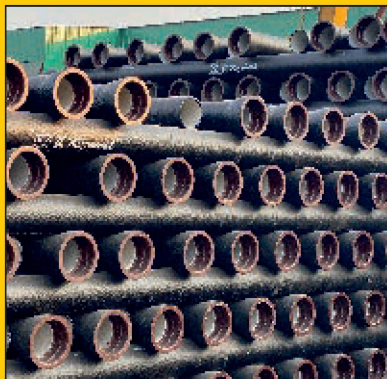

Pyramid Stacking :

Each pipes is adjusted Between two pipes Immediately beneath it. The axes of all pipes should be in the same direction suitable for all sizes.



Parallel Stacking :

Two timber shall be placed across the pipes between each tier, for all dia pipes.



Storage of Pipes and Gaskets

PIPE STORAGE

General recommendations:

- The storage must be flat. The ground must not be marshy or unstable and it must not contain any corrosive material.
- On arrival in storage area the goods must be inspected, if there is any damage (degradation of internal and external coating), it must be repaired before going into stock.
- The pipe must be stocked in the respective stacks according to diameter in accordance with a logical stock plan
- It is always desirable to protect coating from the effects of weathering and prolonged exposure in the sun.
- 'U' shaped hooks covered with special protection of plastic material or rubber, to avoid any damage to the internal coating of pipes. Wooden spacers (timber, wedges etc.) must be strong enough and of good quality.
- Precaution must be taken when the pipes have special coating.

STORAGE OF GASKETS

As per standard mainly the ring shall be stored in accordance with the following precautionary measures:

- Storage temperature should be below 25°C and preferably below 15°C
- Elastomer rubber should be protected from light, direct sunlight and strong artificial light with a high ultraviolet content.
- As zone is particularly deleterious, storage room

should not contain any equipment which is capable of generating ozone such as mercury vapour lamps, high voltage electrical equipment, electric motors or other equipments which may cause electric spark or silent electrical discharge.

- Elastomer rubber should be stored on a normal position that is free from tension, compression and other deformation.

The maximum period for dispatching gaskets of the water type from the works or store of Kejriwal is fixed at three years after manufacturing.



SAFETY PRECAUTIONS

- Wear helmet, gloves & safety shoes.
- Periodically inspect & replace wire ropes & slings.
- Be careful not to hit pipes & fittings against hard objects.
- Pipes/Fittings may spin if wire rope is twisted.
- Always place chocks of timbers to prevent pipes from rolling off.
- Occasionally inspect the condition of timbers.
- Always use forklift for moving the pipes.



INSTALLATION GUIDELINES

- Cleanliness of all parts
- Correct location of all components
- Centralisation of spigot with socket.
- Correct lubrication of joint components
- Glands & Gaskets should be wiped clean & inspected for damage.
- Inner portion of socket of both pipes & fittings, where rubber gaskets will be inserted, to be wiped clean with dry cloth
- All the fittings should be matched with the dia properly before installing.



DN	Max. Stack Layers (No of Pipes)	DN	Max. Stack Layers (No of Pipes)
80	18	400	7
100	16	450	7
150	14	500	6
200	12	600	4
250	10	700	3
300	8	750+	2
350	8		







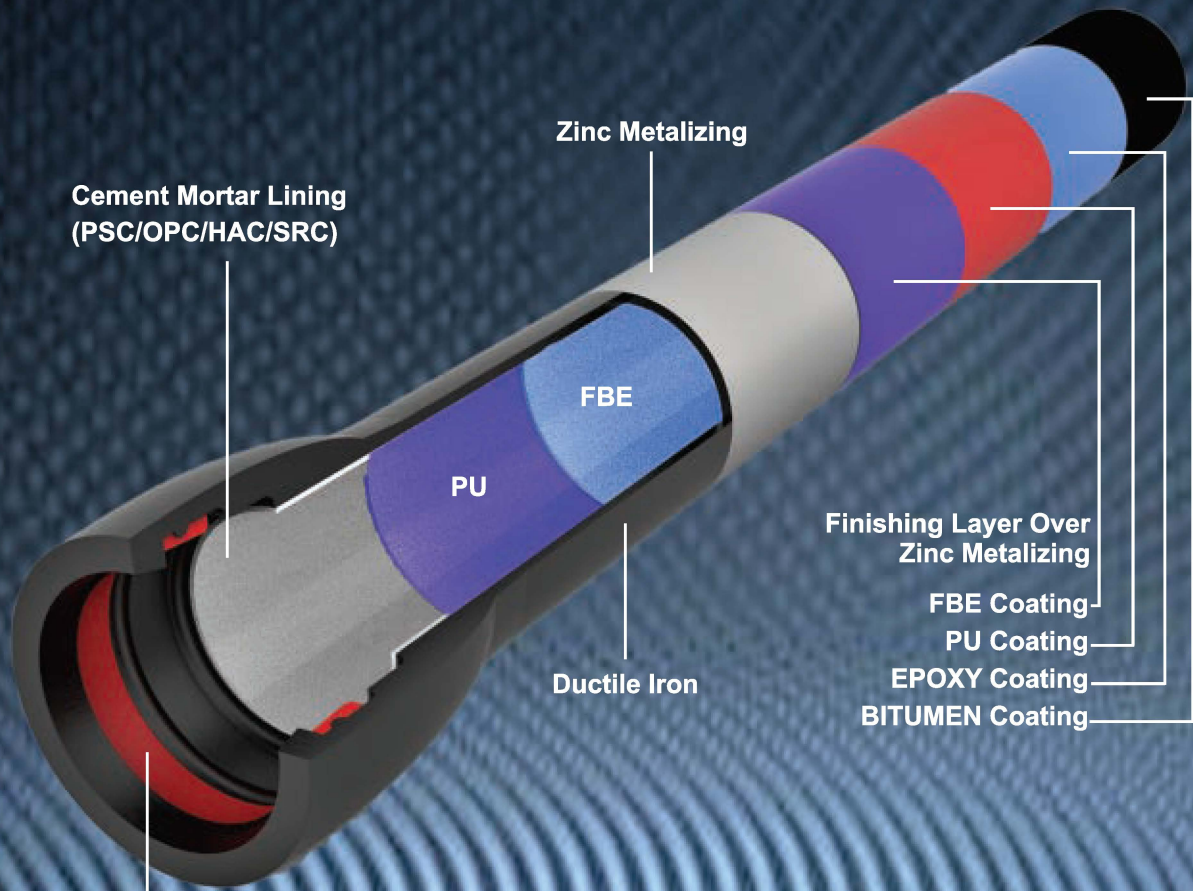

Cement Mortar Lining
(PSC/OPC/HAC/SRC)

Zinc Metalizing

PU

FBE

Ductile Iron

Finishing Layer Over
Zinc Metalizing

FBE Coating

PU Coating

EPOXY Coating

BITUMEN Coating

EPDM
Rubber Ring



ISO 9001-2015



Accredited Management Systems Certification Body MSCB-119

ISO 14001:2015



Accredited Management Systems Certification Body MSCB-119

ISO 45001:2018

Millenium City
DN 62, Salt Lake
Sector - V, 14th Floor
Tower 2
Kolkata 700091
Bharat (India)

Phone: 033 4801 6753/5964
033 4804 0845/0849

E-mail: info@kejriwalcastings.com
Website: www.kejriwalcastings.com

Works Unit I :
NH-6, Chamrail,
Howrah - 711 114
West Bengal
Bharat (India)
Phone : +91 0321 2247244
+91 0321 2247527

Works Unit II :
Bamunara Industrial Estate
Bamunara, Durgapur 713 212
West Bengal
Bharat (India)

Kejriwal CASTINGS LIMITED

Mfg. of Ductile Iron, Cast Iron Pipes, Fittings, Valves Etc

You name it. We cast it !